

Operating Instructions

# METRAPHASE 1

Phase Sequence Indicator

3-348-991-37

10/6.11



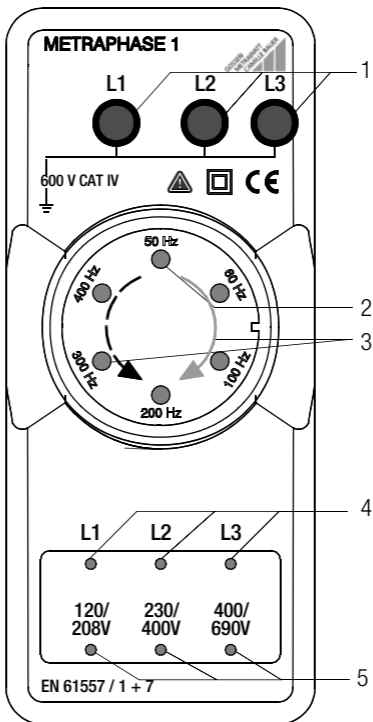

- (1) Connector sockets for phases L1 ... L3
- (2) **Rotation LEDs** for frequency display and direction of phase rotation
- (3) **Direction of Phase Rotation and Frequency**  
**Green arrow:** clockwise rotation;  
indicates correct phase sequence  
Illuminated green LEDs rotate clockwise.  
**Frequency:**  
Indicated by brief, red illumination of corresp. LED.  
**Dashed red arrow:** counterclockwise rotation;  
indicates incorrect phase sequence  
Illuminated red LEDs rotate counterclockwise.  
**Frequency:**  
Indicated by brief, green illumination of corresponding LED.
- (4) **Phase LEDs**, indicate voltage at L1 ... L3
- (5) **Voltage value LEDs**, indicate value of line-to-line voltage

|  | Page      |
|--|-----------|
| <b>1 Safety Precautions .....</b>  | <b>3</b>  |
| <b>2 Application .....</b>   | <b>5</b>  |
| <b>3 Initial Start-Up .....</b>  | <b>5</b>  |
| <b>4 Operation .....</b>   | <b>6</b>  |
| 4.1 Voltage Display .....  | 6         |
| 4.2 3-Pole Connection .....  | 6         |
| 4.3 2-Pole Connection .....  | 7         |
| <b>5 Characteristic Values, Phase Sequence Indicator .....</b>   | <b>8</b>  |
| <b>6 Maintenance .....</b>   | <b>10</b> |
| 6.1 Batteries .....  | 10        |
| 6.2 Housing .....  | 10        |
| 6.3 Device Return and Environmentally Compatible Disposal ....   | 11        |
| <b>7 Accessories (not included as standard equipment) .....</b>  | <b>11</b> |
| <b>8 Repair and Replacement Parts Service<br/>Calibration Center<br/>and Rental Instrument Service .....</b> | <b>12</b> |
| <b>9 Product Support .....</b>   | <b>12</b> |

## 1 Safety Precautions

### General

This instrument fulfills the requirements of the applicable European and national EC guidelines. We confirm this with the CE marking. The relevant declaration of conformity can be obtained from GMC-I Messtechnik GmbH.

The phase sequence indicator has been manufactured and tested in accordance with safety regulations IEC 61010-1 / DIN EN 61010-1 / VDE 0411-1.

When used for its intended purpose, safety of the operator, as well as that of the instrument, is assured. Their safety is however not guaranteed if the instrument is used improperly or handled carelessly.

In order to maintain flawless technical safety conditions, and to assure safe use, it is imperative that you **read the operating instructions thoroughly and carefully before placing your instrument into service, and that you follow all instructions contained therein.**

### Repair and Parts Replacement

When the instrument is opened, voltage conducting parts may be exposed. The instrument must be disconnected from the measuring circuit or the device under test before maintenance or the replacement of parts.

The following safety precautions must be observed:

- The instrument may only be operated by persons who are capable of recognizing contact hazards and taking the appropriate safety precautions. Contact hazards exist anywhere, where voltages of greater than 30 V r.m.s. may occur.
- Avoid working alone when taking measurements which involve contact hazards. Be certain that a second person is present.
- Make certain that the measurement cables are in flawless condition, and that they do not suffer from damage to the conductors or their insulation. This applies to test probes and alligator clips as well.
- No measurements may be made with this instrument in electrical circuits with corona discharge (high-voltage).
- Measurements under moist ambient conditions are not permitted, nor are their results reliable.
- Use the recommended batteries.
- The instrument is not a voltmeter in the usual sense of the word: it only reads out voltages within the indicated ranges.

### Errors and Extraordinary Strains

If it may be assumed that the instrument can no longer be operated safely, it must be removed from service and secured against further use.

Safe operation can no longer be relied upon,

- if the instrument demonstrates visible damage,
- if the instrument no longer functions.

### Meanings of Symbols on the instrument



Warning concerning a point of danger  
(Attention: observe documentation)



Earth



Continuous, double or reinforced  
insulation

**CAT IV**

The **maximum allowable voltage** between any given connector jack (1) and earth is equal to **600 V, category IV**.



Indicates EU conformity



This device may not be disposed of with the trash. Further information regarding the WEEE mark can be accessed on the Internet at [www.gossen-metrawatt.com](http://www.gossen-metrawatt.com) by entering the search term 'WEEE'.

## 2 Application

The instrument provides for the following measurement and test functions:

- Phase sequence indicator
- Voltage display
- Frequency display

In conformity with standard DIN EN 61010-031, measurements in an environment according to measuring category III and IV may only be performed with the **safety cap** applied to the test probe of the measurement cable.

For establishing contact in 4 mm jacks you have to remove the safety cap by levering out the snap lock of the **safety cap** with another sharp object (e. g. the second test probe).

## 3 Initial Start-Up

### Batteries

The phase sequence indicator is delivered with 4 mignon cells installed and is ready for use. Before initial start-up, please refer to chapter 6.1 "Batteries".

### Battery Test

If none of the LEDs light up after a voltage has been applied, or if they are only faintly illuminated, the batteries must be replaced.

### Automatic Activation

The instrument is activated automatically as soon as a voltage of at least 100 V is applied to any 2 measurement sockets.

### Automatic Shut-Down

The instrument is shut down automatically when zero voltage is applied in order to extend battery service life.

## 4 Operation

### 4.1 Voltage Display

Voltage is displayed by means of 3 red LEDs (5), each of which indicates a different nominal line voltage. The highest voltage which occurs between two phases is always displayed. Voltage is displayed for the following nominal values: 120 V/208 V, 230 V/400 V und 400 V/690 V.

#### Missing or Non-Connected Phase

If one of the phases has not been connected to the phase sequence indicator, or if one phase has not been wired, its potential at artificial neutral is too small and the corresponding phase LED does not light up. However, the voltage value LED which corresponds to line-to-line voltage is illuminated.

**Exception:** If no phase has been connected to terminal L1, the voltage value LED displays the next lowest voltage because the instrument is no longer provided with an internal reference point.



#### Attention!

The L1 jack at the METRAPHASE 1 must always be contacted first, in order to avoid erroneous measurements.

---

### 4.2 3-Pole Connection

#### Symmetrical Clockwise Rotation

When a symmetrical, clockwise phase sequence is measured, phase LEDs L1, L2 and L3 are continuously illuminated and a green point of light (rotation LED) rotates around the display dial in the clockwise direction (at approx. 30 RPM).

#### Symmetrical Counterclockwise Rotation

Phase LEDs L1, L2 and L3 are also continuously illuminated for a symmetrical, counterclockwise phase sequence, but the color and the direction of the rotating point of light are changed: it rotates in the counterclockwise direction and is illuminated red.

#### Frequency Display

The appropriate frequency LED lights up briefly in red for a clockwise phase sequence at the moment the rotating point of light passes the corresponding position. The frequency LED lights up green for a counterclockwise phase sequence.

#### Devices Connected to N or PE

If one of the devices has been connected to N or PE with an asymmetrical phase sequence the phase LED for the incorrectly connected phase does not light up. Phase sequence direction is indicated in the same way as it is for symmetrical clockwise or counterclockwise phase sequences.

#### Wiring Incorrect

If wiring is incorrect, e.g. 2 x L1, ambiguous displays are likely to occur.

### 4.3 2-Pole Connection

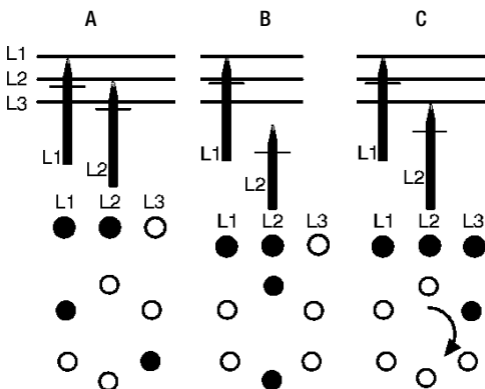

The phase sequence indicator also allows for the determination of phase sequence direction with only 2 connector cables, as long as a line frequency of 50 or 60 Hz prevails:

- Ⓓ First connect terminal L1 to phase L1, and terminal L2 to phase L2 (see figure A). Phase LEDs L1 and L2, as well as the corresponding voltage value LED, light up red. The two LEDs for 100 and 400 Hz are also illuminated, which indicates that the instrument has synchronized itself to phases L1 and L2.
- Ⓓ Disconnect phase L2 from terminal L2 (see figure B). The two LEDs for 50 and 200 Hz light up during this intermediate stage.
- Ⓓ Now connect phase L3 to terminal L2 (see figure C). Phase LEDs L1 and L3 light up red. L2 is generated internally. Phase sequence direction and line voltage value are displayed.



#### Note!

Approximately 2 seconds are allowed for changing over from L2 to L3. If this time period is exceeded, the instrument is no longer able to maintain synchronization with the electrical system. This error is indicated by means of simultaneous illumination of the LEDs for 60, 100, 300 and 400 Hz. The LEDs for 100 and 400 Hz are then illuminated in order to indicate that 2-pole measurement has been resumed. The same display occurs if phase L2 is inadvertently reconnected instead of changing to phase L3.

## 5 Characteristic Values, Phase Sequence Indicator

### Line Frequency

| Nominal Frequency    | Display Range      | Tolerance Band     | Display                           |
|----------------------|--------------------|--------------------|-----------------------------------|
| 50 Hz <sup>1)</sup>  | 49.4 ... 50.7 Hz   | 49.2 ... 50.9 Hz   | <b>50 Hz LED is active</b>        |
| —                    | 51.1 ... 57.9 Hz   | 50.9 ... 58.1 Hz   | 50 Hz and 60 Hz LEDs are active   |
| 60 Hz                | 58.3 ... 61.0 Hz   | 58.1 ... 61.2 Hz   | <b>60 Hz LED is active</b>        |
| —                    | 61.4 ... 97.3 Hz   | 61.2 ... 97.5 Hz   | 60 Hz and 100 Hz LEDs are active  |
| 100 Hz               | 97.7 ... 102.8 Hz  | 97.5 ... 103 Hz    | <b>100 Hz LED is active</b>       |
| —                    | 103.2 ... 195 Hz   | 103 ... 195.2 Hz   | 100 Hz and 200 Hz LEDs are active |
| 200 Hz               | 195.4 ... 205.6 Hz | 195.2 ... 205.8 Hz | <b>200 Hz LED is active</b>       |
| —                    | 206 ... 298.6 Hz   | 205.8 ... 298.8 Hz | 200 Hz and 300 Hz LEDs are active |
| 300 Hz               | 299 ... 303.4 Hz   | 298.8 ... 303.6 Hz | <b>300 Hz LED is active</b>       |
| —                    | 303.8 ... 395.3 Hz | 303.6 ... 395.5 Hz | 300 Hz and 400 Hz LEDs are active |
| 400 Hz <sup>1)</sup> | 395.7 ... 405.8 Hz | 395.5 ... 406 Hz   | <b>400 Hz LED is active</b>       |

<sup>1)</sup> < 50 Hz/> 400 Hz: both LEDs active

Total frequency range 15 ... 410 Hz

Total line voltage 100 ... 690 V

### 3 Phase ~Line Voltage

| Nominal Line Voltage LED Display | Corresponding L-L Voltage | Corresponding L-N Voltage |
|----------------------------------|---------------------------|---------------------------|
| 120/208V                         | 180 ... 300 V             | 104 ... 173 V             |
| 230/400V                         | 360 ... 470 V             | 208 ... 271 V             |
| 400/690V                         | 530 ... 800 V             | 306 ... 462 V             |

### Phase Sequence Direction

| Phase Direction   | Phase Sequence      | Display at Phase LEDs                                    | Display at Rotation LEDs   |
|-------------------|---------------------|--|--|
| <b>Clockwise</b>  | <b>L1 - L2 - L3</b> | <b>L1 L2 L3 light up</b>                                 | <b>green LED rotates in clockwise direction</b>                                  |
| Counter-clockwise | L3 - L2 - L1        | L1 L2 L3 light up  | red LED rotates in counterclockwise direction                                    |
| Asymmetrical      | Lx - N/PE - Lx      | connection with N/PE not indicated                       | green or red LED rotates clockwise or counterclockwise depending upon connection |
| Phase Missing     | Lx - X - Lx         | missing phase does not light up, the other 2 do light up | —  |



## Reference Conditions

|                           |  |
|---------------------------|--|
| Ambient Temperature       | +23 °C ±2 K  |
| Relative Humidity         | 40 ... 60 %  |
| Battery Voltage           | 4.5 V ±0.25 V  |
| Line Voltage              | 230/400 V ±0.5 %   |
| Line Frequency            | 50 Hz ±0.1 Hz  |
| Line Voltage<br>Waveshape | sine, deviation between effective<br>and rectified value < 1 % |

## Ambient Conditions

|                       |                           |
|-----------------------|---------------------------|
| Storage Temperature   | -25 °C ... +75 °C         |
| Operating Temperature | -10 °C ... +50 °C         |
| Relative Humidity     | max. 75%, no condensation |
| Altitude              | to 2000 m                 |

## Power Supply

|                      |   |
|----------------------|---|
| Battery              | 4 mignon cells, alkaline-<br>manganese per IEC LR6<br>(4 x AA-Size)<br>or 4 mignon cells, zinc-carbon<br>per IEC R6 |
| Battery Voltage      | 4 V ... 6 V   |
| Battery Service Life | approx. 100 hours<br>with alkaline-manganese cells  |

## Electrical Safety

|                    |                    |
|--------------------|--------------------|
| Protection Class   | II per IEC 61010-1 |
| Measuring Category | IV                 |
| Operating Voltage  | 600 V              |
| Pollution Degree   | 2                  |
| Test Voltage       | 5.55 kV            |

## Electromagnetic Compatibility

|                       |                         |
|-----------------------|-------------------------|
| Interference Emission | EN 61326-1:2006 Class B |
| Interference Immunity | EN 61326-1:2006         |

## Mechanical Design

|            |  |
|------------|--|
| Protection | IP40 per DIN VDE 0470 Part 1/<br>EN 60529<br>Extract from table on the signifi-<br>cance of IP codes |
|------------|--|

| IP XY<br>(1 <sup>st</sup> digit X) | Protection against the<br>penetration of solid<br>foreign matter | IP XY<br>(2 <sup>nd</sup> digit Y) | Protection against the<br>penetration of water |
|------------------------------------|--|------------------------------------|--|
| 4                                  | ≥ 1.0 mm Ø   | 0                                  | no protection                                  |

|            |   |
|------------|---|
| Dimensions | 84 mm x 195 mm x 35 mm  |
| Weight     | approx. 0.3 kg with batteries,<br>without protective rubber cover |

## 6 Maintenance

### 6.1 Batteries

---



#### Attention!

Disconnect the instrument from the measuring circuit before opening to replace batteries.

---

Before initial start-up and after any period of storage, make certain that no battery leakage has occurred. Inspect for battery leakage at regular intervals as well.

If battery leakage has occurred, the electrolyte from the batteries must be carefully and completely removed with a damp cloth, and the batteries must be replaced before the instrument is placed back into service.

If none of the LEDs light up after a voltage has been applied, or if they are only faintly illuminated, the batteries must be replaced.

The instrument requires four 1.5 V batteries in accordance with IEC or equivalent rechargeable batteries.

#### Replacing the Batteries

Lay the instrument onto its face, loosen both of the screws at the rear panel and lift out the housing base starting at the side at which the screws are located. The housing base and housing top are fastened together by means of snap hooks at the other side.

Replace the batteries in the battery holder with 4 new batteries.

Replace the housing base starting at the side with the snap hooks and make certain that they are properly engaged.

Refasten the housing base with the two screws.

Please dispose of depleted batteries in an environmentally sound fashion, for example at an appropriate collection depot.

---



#### Note!

The phase sequence indicator is not equipped with any fuses!

---

### 6.2 Housing

No special maintenance is required for the housing. Keep outside surfaces clean. Use a slightly dampened cloth for cleaning. Avoid the use of cleansers, abrasives or solvents.

### 6.3 Device Return and Environmentally Compatible Disposal

The **instrument** is a category 9 product (monitoring and control instrument) in accordance with ElektroG (German Electrical and Electronic Device Law). This device is not subject to the RoHS directive.

We identify our electrical and electronic devices (as of August 2005) in accordance with WEEE 2002/96/EG and ElektroG with the symbol shown to the right per DIN EN 50419.



These devices may not be disposed of with the trash. Please contact our service department regarding the return of old devices.

If you use **batteries** or **rechargeable batteries** in your instrument or accessories which no longer function properly, they must be duly disposed of in compliance with the applicable national regulations.

Batteries or rechargeable batteries may contain harmful substances or heavy metal such as lead (Pb), cadmium (Cd) or mercury (Hg).

The symbol shown to the right indicates that batteries or rechargeable batteries may not be disposed of with the trash, but must be delivered to collection points specially provided for this purpose.



## 7 Accessories (not included as standard equipment)

### Variable Plug Adapter Set (article no. Z500A)



Three self-retaining, contact-protected test probes for the connection of measurement cables with 4 mm banana plugs or with contact-protected plugs for 3.5 to 12 mm outlets, e.g. CEE outlets, Perilex outlets etc.

For example, the test probes fit into the square PE sockets at Perilex outlets. Maximum allowable operating voltage: 600 V per IEC 61010.

## **8 Repair and Replacement Parts Service Calibration Center and Rental Instrument Service**

When you need service, please contact:

GMC-I Service GmbH

### **Service Center**

Thomas-Mann-Strasse 20

90471 Nürnberg • Germany

Phone +49 911 817718-0

Fax +49 911 817718-253

E-mail [service@gossenmetrawatt.com](mailto:service@gossenmetrawatt.com)

[www.gmci-service.com](http://www.gmci-service.com)

This address is for Germany only. Abroad, our representatives or establishments are at your disposal.

## **9 Product Support**

When you need support, please contact:

GMC-I Messtechnik GmbH

### **Product Support Hotline**

Phone +49 911 8602-0

Fax +49 911 8602-709

E-Mail [support@gossenmetrawatt.com](mailto:support@gossenmetrawatt.com)

---

Edited in Germany • Subject to change without notice • A PDF version is available on the Internet



GMC-I Messtechnik GmbH

Südwestpark 15

90449 Nürnberg • Germany

Phone +49 911 8602-111

Fax +49 911 8602-777

E-Mail [info@gossenmetrawatt.com](mailto:info@gossenmetrawatt.com)

[www.gossenmetrawatt.com](http://www.gossenmetrawatt.com)